

# Chapter 6

## The Link Layer and LANs

---

### A note on the use of these Powerpoint slides:

We're making these slides freely available to all (faculty, students, readers). They're in PowerPoint form so you see the animations; and can add, modify, and delete slides (including this one) and slide content to suit your needs. They obviously represent a *lot* of work on our part. In return for use, we only ask the following:

- If you use these slides (e.g., in a class) that you mention their source (after all, we'd like people to use our book!)
- If you post any slides on a www site, that you note that they are adapted from (or perhaps identical to) our slides, and note our copyright of this material.

Thanks and enjoy! JFK/KWR

© All material copyright 1996-2016  
J.F Kurose and K.W. Ross, All Rights Reserved

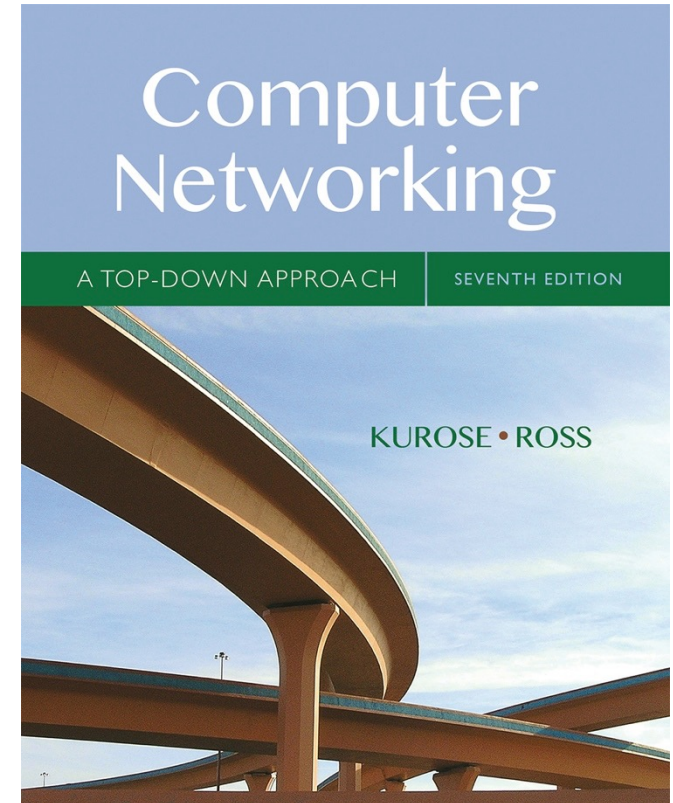

## Computer Networking: A Top Down Approach

7<sup>th</sup> edition

Jim Kurose, Keith Ross

Pearson/Addison Wesley

April 2016

# Link layer, LANs: outline

6.1 introduction, services

6.2 error detection,  
correction

6.3 multiple access  
protocols

## 6.4 LANs

- addressing, ARP
- Ethernet
- switches
- VLANs

6.5 link virtualization:  
MPLS

6.6 data center  
networking

6.7 a day in the life of a  
web request

# Ethernet

“dominant” wired LAN technology:

- single chip, multiple speeds (e.g., Broadcom BCM5761)
- first widely used LAN technology
- simpler, cheap
- kept up with speed race: 10 Mbps – 10 Gbps

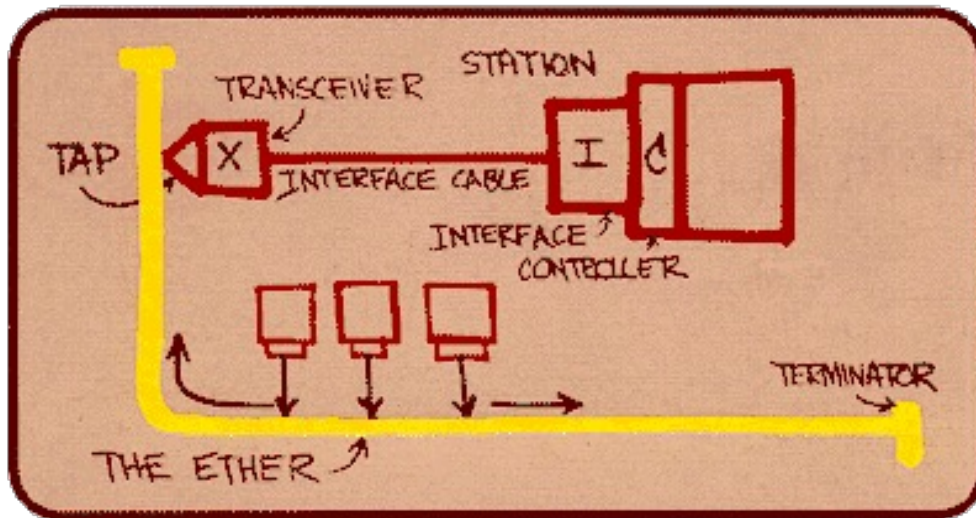

*Metcalfe's Ethernet sketch*

# Ethernet: physical topology

- **bus:** popular through mid 90s
  - all nodes in same collision domain (can collide with each other)
- **star:** prevails today
  - active **switch** in center
  - each “spoke” runs a (separate) Ethernet protocol (nodes do not collide with each other)

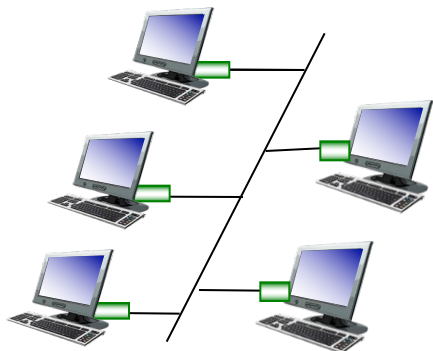

**bus:** coaxial cable

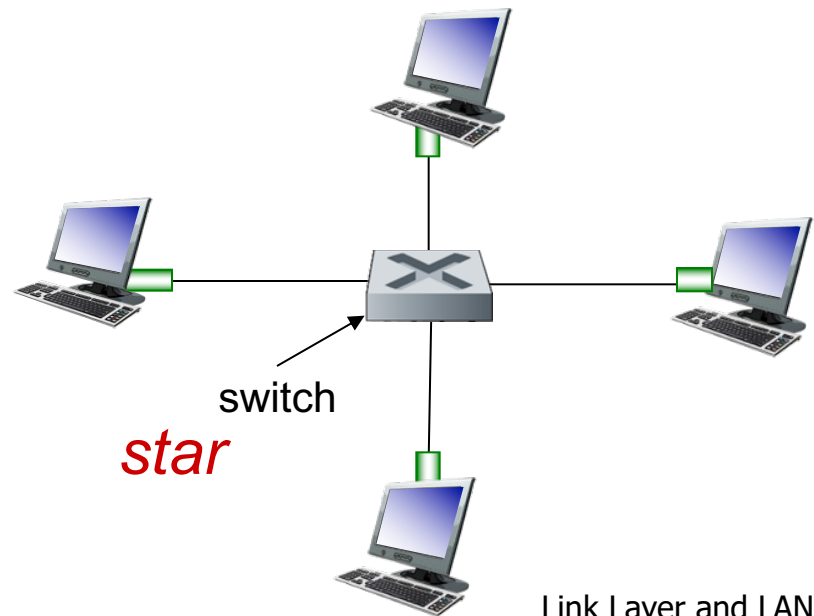

**star**

# Ethernet frame structure

sending adapter encapsulates IP datagram (or other network layer protocol packet) in **Ethernet frame**



## *preamble:*

- 7 bytes with pattern 10101010 followed by one byte with pattern 10101011
- used to synchronize receiver, sender clock rates

# Ethernet frame structure (more)

- **addresses:** 6 byte source, destination MAC addresses
  - if adapter receives frame with matching destination address, or with broadcast address (e.g. ARP packet), it passes data in frame to network layer protocol
  - otherwise, adapter discards frame
- **type:** indicates higher layer protocol (mostly IP but others possible, e.g., Novell IPX, AppleTalk)
- **CRC:** cyclic redundancy check at receiver
  - error detected: frame is dropped



# Ethernet: unreliable, connectionless

- *connectionless*: no handshaking between sending and receiving NICs
- *unreliable*: receiving NIC doesn't send acks or nacks to sending NIC
  - data in dropped frames recovered only if initial sender uses higher layer rdt (e.g., TCP), otherwise dropped data lost
- Ethernet's MAC protocol: unslotted *CSMA/CD with binary backoff*

# 802.3 Ethernet standards: link & physical layers

- *many* different Ethernet standards
  - common MAC protocol and frame format
  - different speeds: 2 Mbps, 10 Mbps, 100 Mbps, 1 Gbps, 10 Gbps, 40 Gbps
  - different physical layer media: fiber, cable

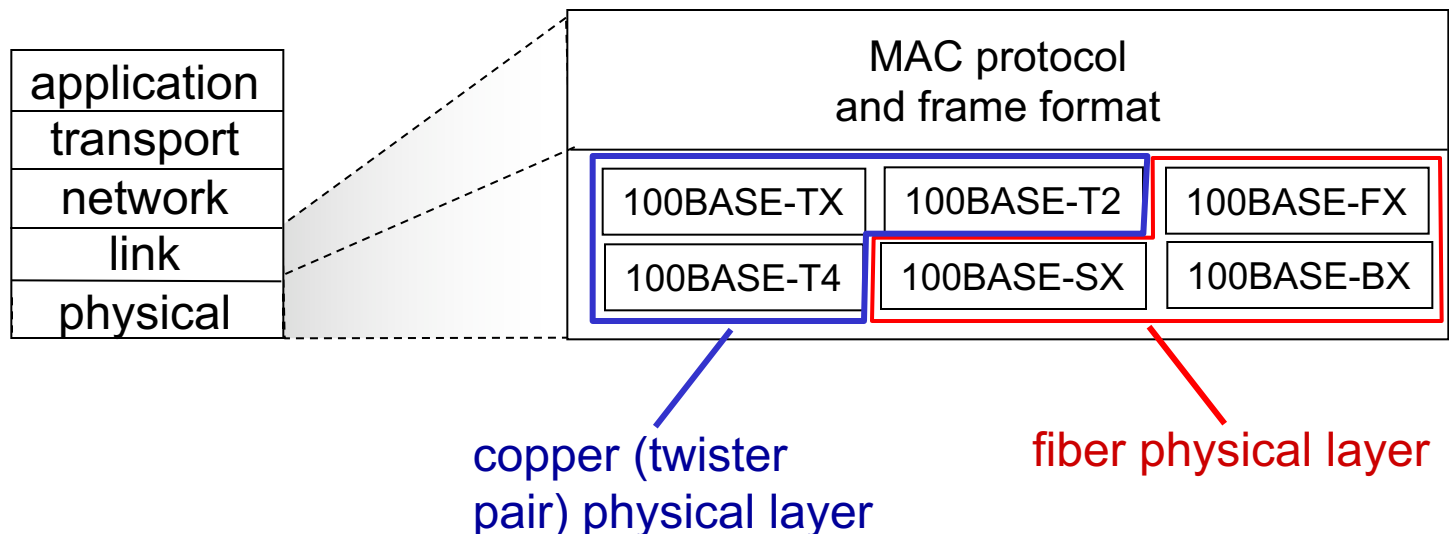



# Link layer, LANs: outline

6.1 introduction, services

6.2 error detection,  
correction

6.3 multiple access  
protocols

## 6.4 LANs

- addressing, ARP
- Ethernet
- switches
- VLANs

6.5 link virtualization:  
MPLS

6.6 data center  
networking

6.7 a day in the life of a  
web request

# Ethernet switch

- **link-layer device: takes an *active* role**
  - store, forward Ethernet frames
  - examine incoming frame's MAC address, **selectively** forward frame to one-or-more outgoing links when frame is to be forwarded on segment, uses CSMA/CD to access segment
- ***transparent***
  - hosts are unaware of presence of switches
- ***plug-and-play, self-learning***
  - switches do not need to be configured

# Switch: *multiple* simultaneous transmissions

- hosts have dedicated, direct connection to switch
- switches buffer packets
- Ethernet protocol used on *each* incoming link, but no collisions; full duplex
  - each link is its own collision domain
- **switching:** A-to-A' and B-to-B' can transmit simultaneously, without collisions

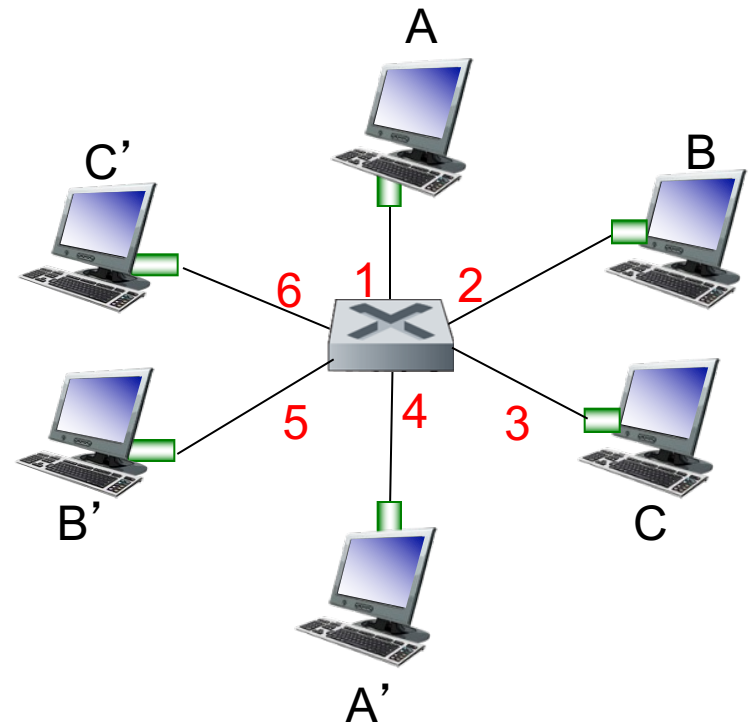

*switch with six interfaces  
(1,2,3,4,5,6)*

# Switch forwarding table

**Q:** how does switch know A' reachable via interface 4, B' reachable via interface 5?

- **A:** each switch has a **switch table**, each entry:
  - (MAC address of host, interface to reach host, time stamp)
  - looks like a routing table!

**Q:** how are entries created, maintained in switch table?

- something like a routing protocol?

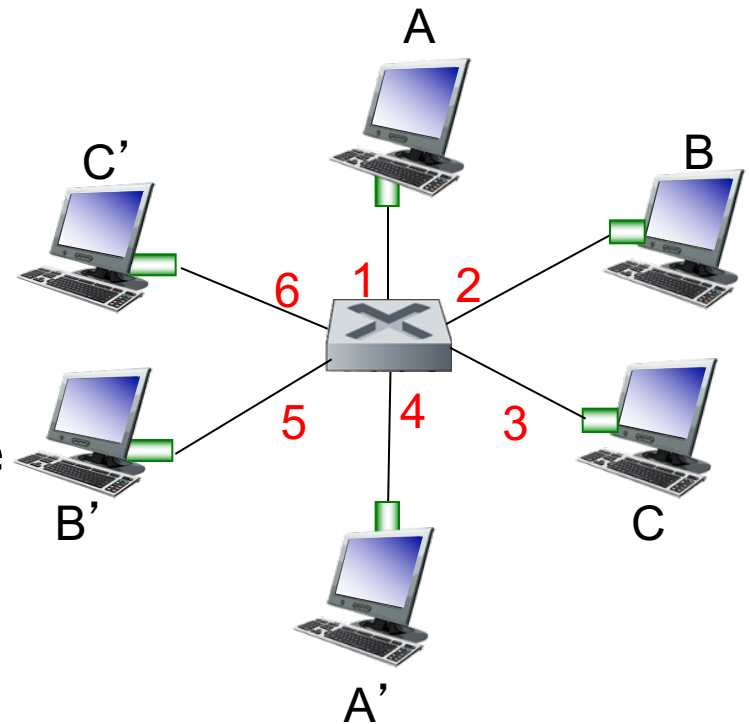

*switch with six interfaces  
(1,2,3,4,5,6)*

# Switch: self-learning

- switch *learns* which hosts can be reached through which interfaces
  - when frame received, switch “learns” location of sender: incoming LAN segment
  - records sender/location pair in switch table

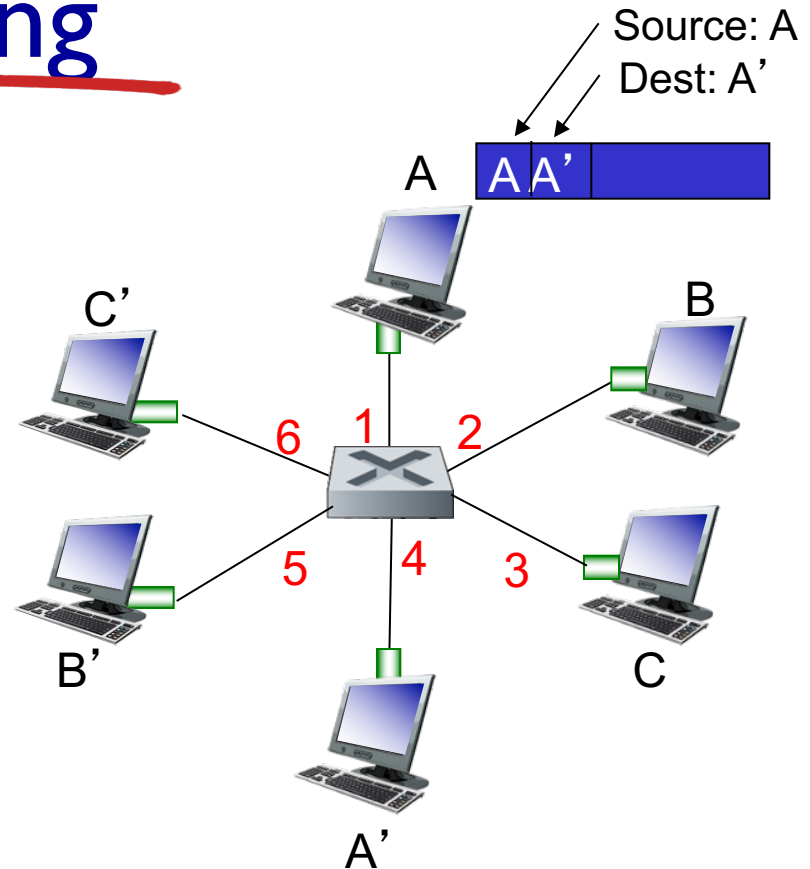

MAC addr	interface	TTL
A	1	60

*Switch table  
(initially empty)*

# Switch: frame filtering/forwarding

when frame received at switch:

1. record incoming link, MAC address of sending host
2. index switch table using MAC destination address

3. if entry found for destination  
then {

if destination on segment from which frame arrived  
then drop frame

else forward frame on interface indicated by entry

}

else flood /\* forward on all interfaces except arriving  
interface \*/

# Self-learning, forwarding: example

- frame destination, A', location unknown: *flood*
- destination A location known: *selectively send on just one link*

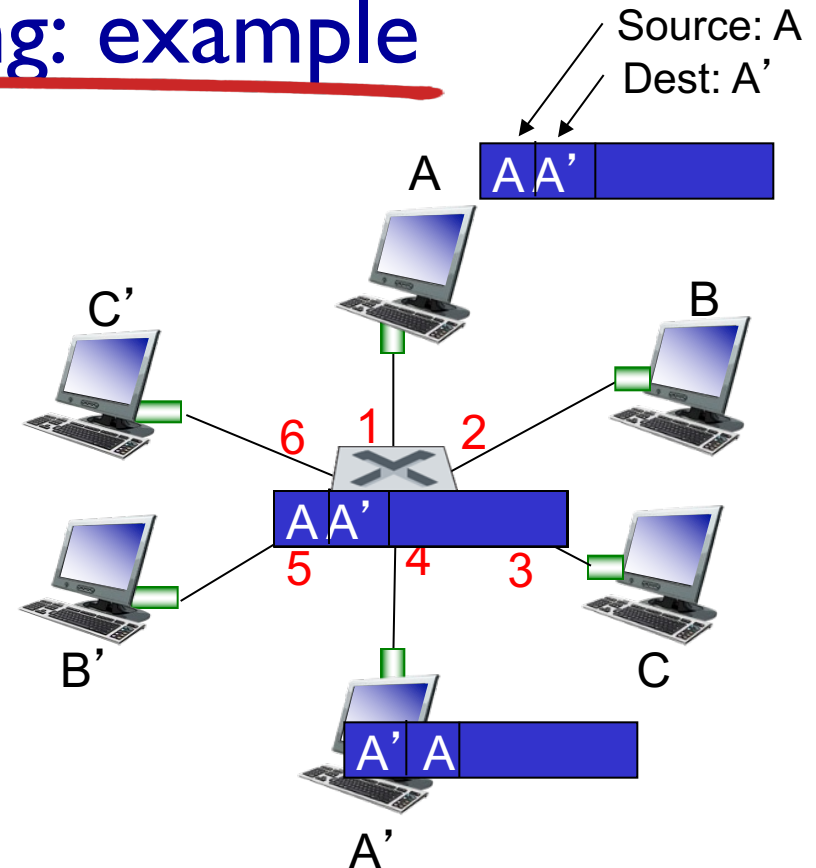

MAC addr	interface	TTL
A	1	60
A'	4	60

*switch table  
(initially empty)*

# Interconnecting switches

self-learning switches can be connected together:

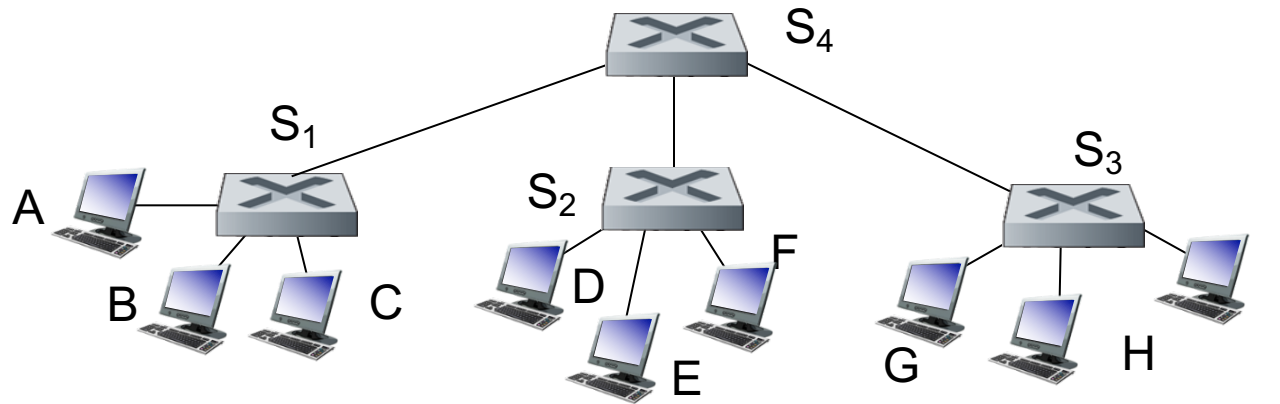

**Q:** sending from A to G - how does S<sub>1</sub> know to forward frame destined to G via S<sub>4</sub> and S<sub>3</sub>?

- **A:** self learning! (works exactly the same as in single-switch case!)



# Self-learning multi-switch example

Suppose C sends frame to I, I responds to C

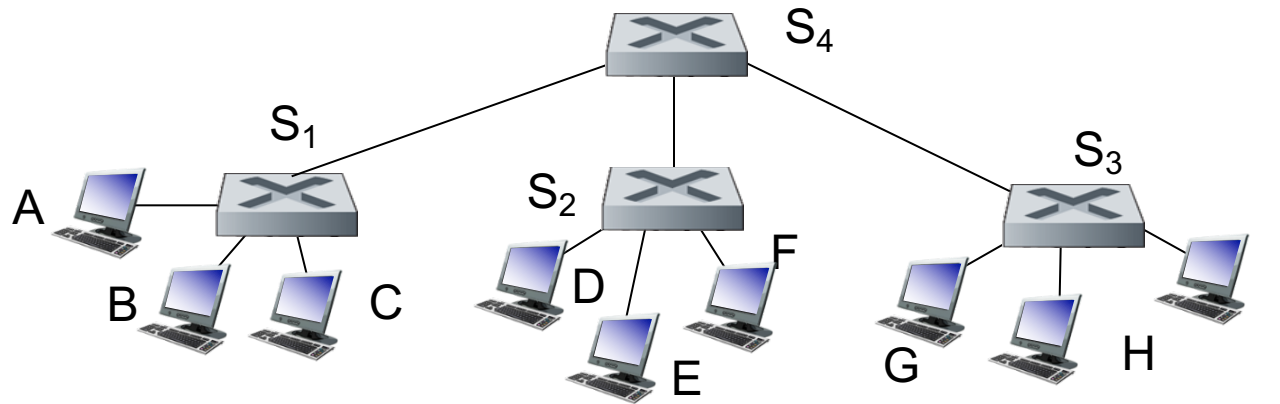

- Q: show switch tables and packet forwarding in S<sub>1</sub>, S<sub>2</sub>, S<sub>3</sub>, S<sub>4</sub>

# Institutional network

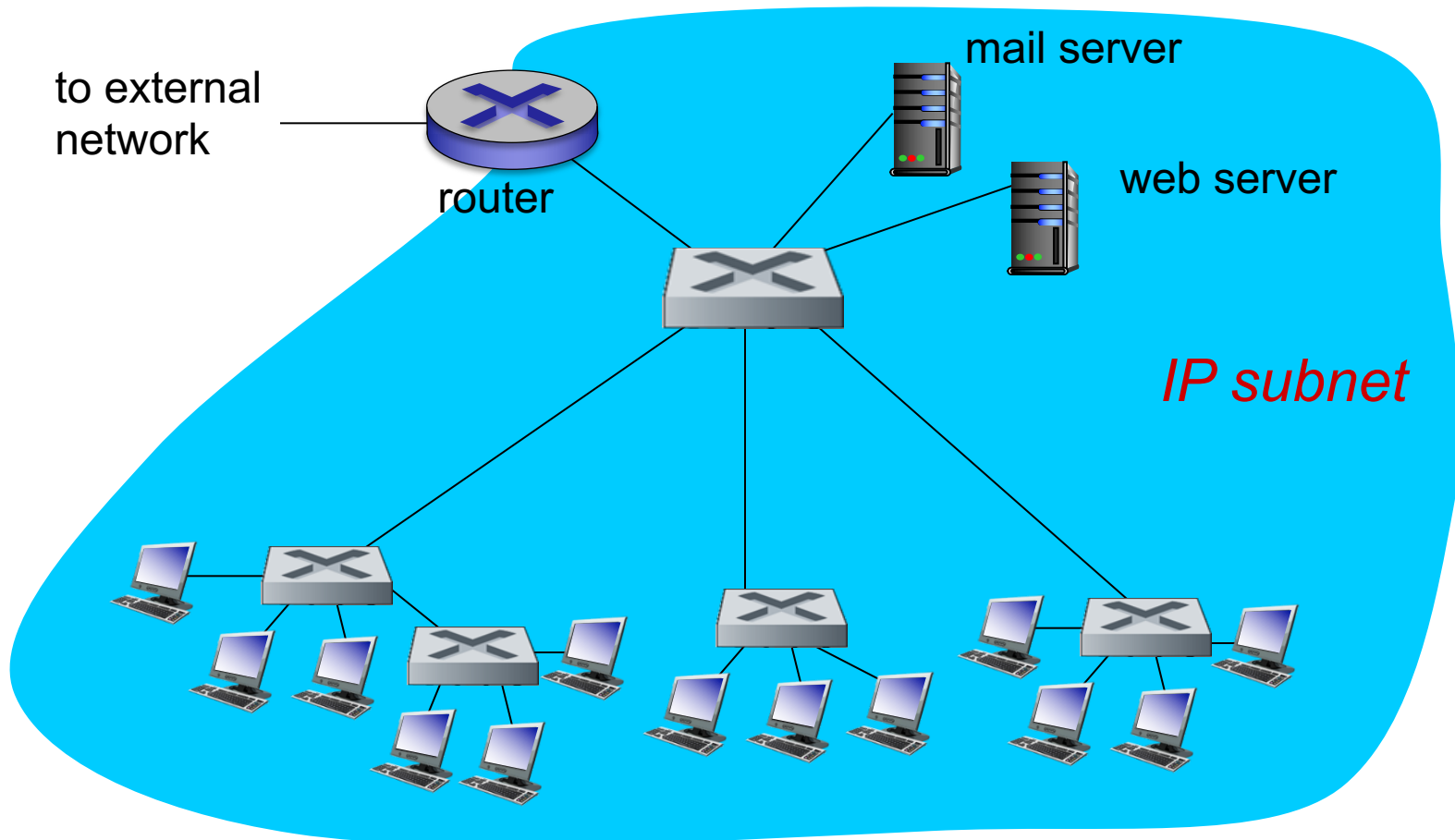

# Switches vs. routers

both are store-and-forward:

- **routers:** network-layer devices (examine network-layer headers)
- **switches:** link-layer devices (examine link-layer headers)

both have forwarding tables:

- **routers:** compute tables using routing algorithms, IP addresses
- **switches:** learn forwarding table using flooding, learning, MAC addresses

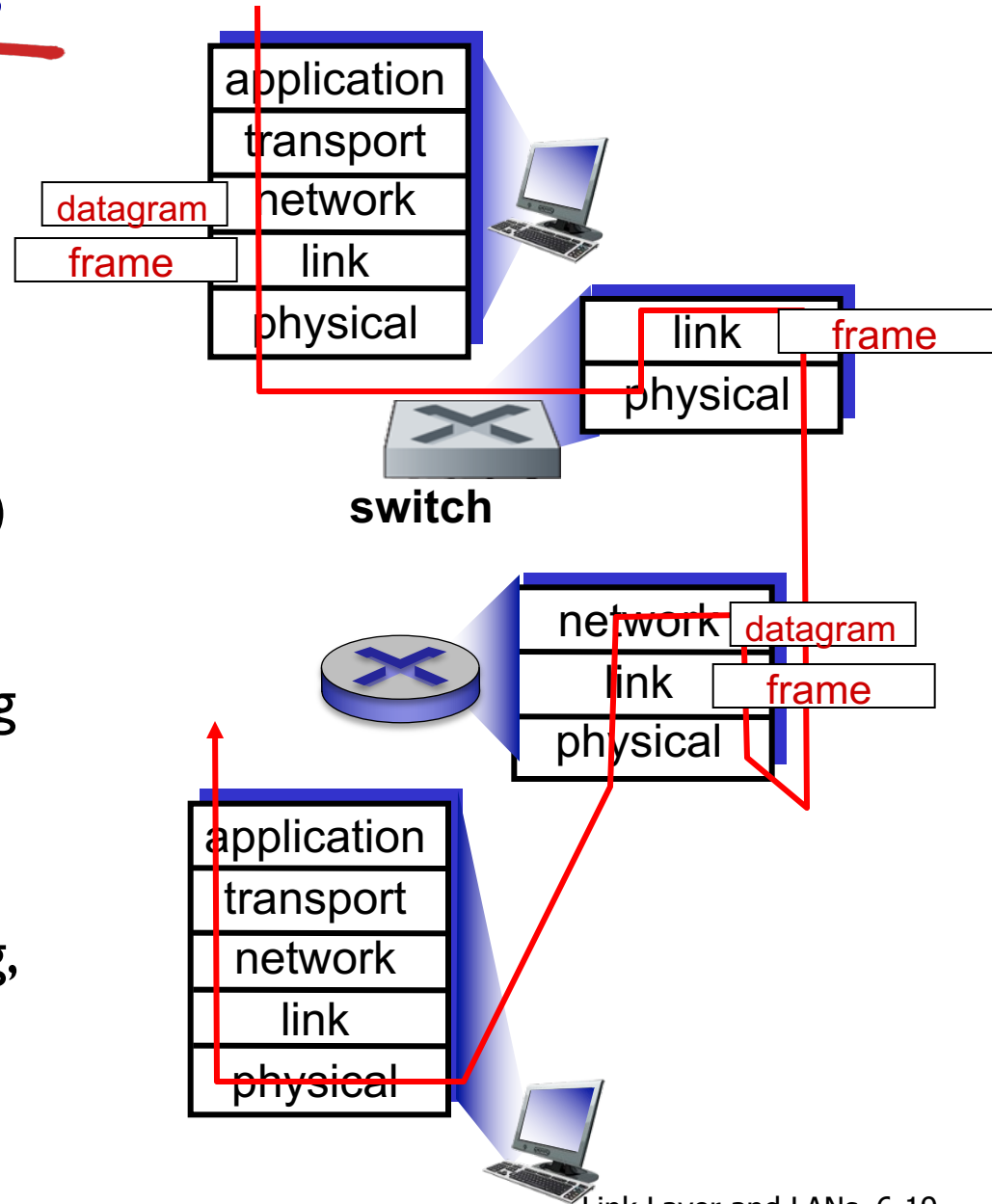

# VLANs: motivation

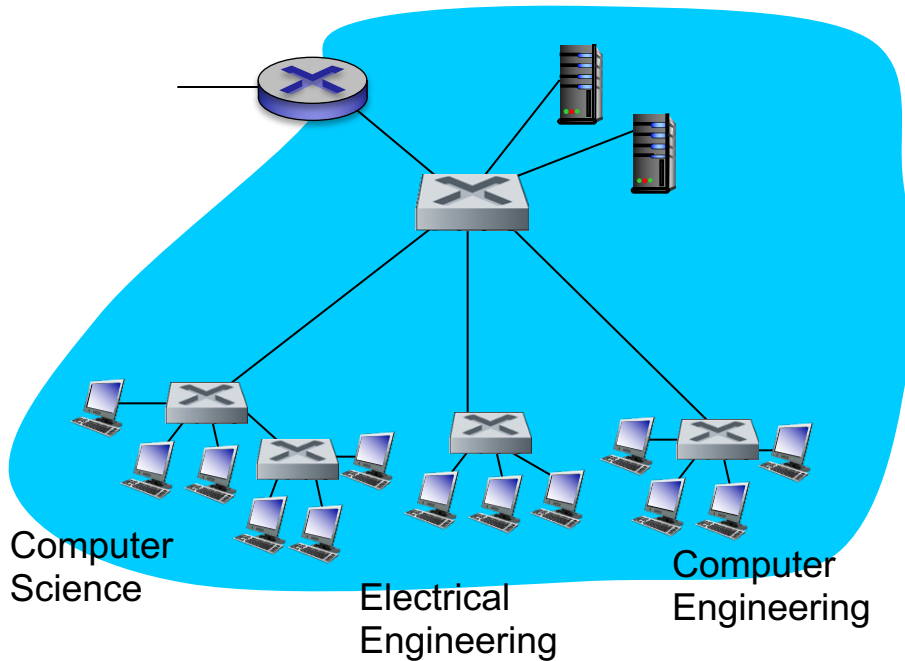

*consider:*

- CS user moves office to EE, but wants connect to CS switch?
- single broadcast domain:
  - all layer-2 broadcast traffic (ARP, DHCP, unknown location of destination MAC address) must cross entire LAN
  - security/privacy, efficiency issues

# VLANs

## *Virtual Local Area Network*

switch(es) supporting VLAN capabilities can be configured to define multiple *virtual* LANs over single physical LAN infrastructure.

**port-based VLAN:** switch ports grouped (by switch management software) so that *single* physical switch .....

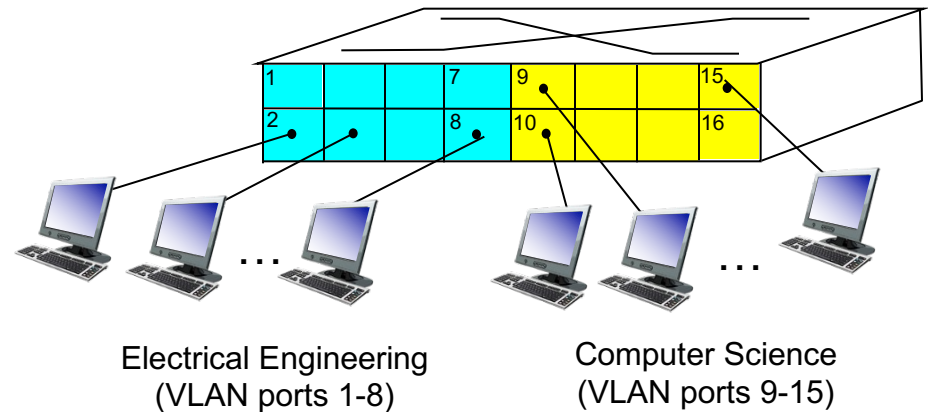

... operates as **multiple** virtual switches

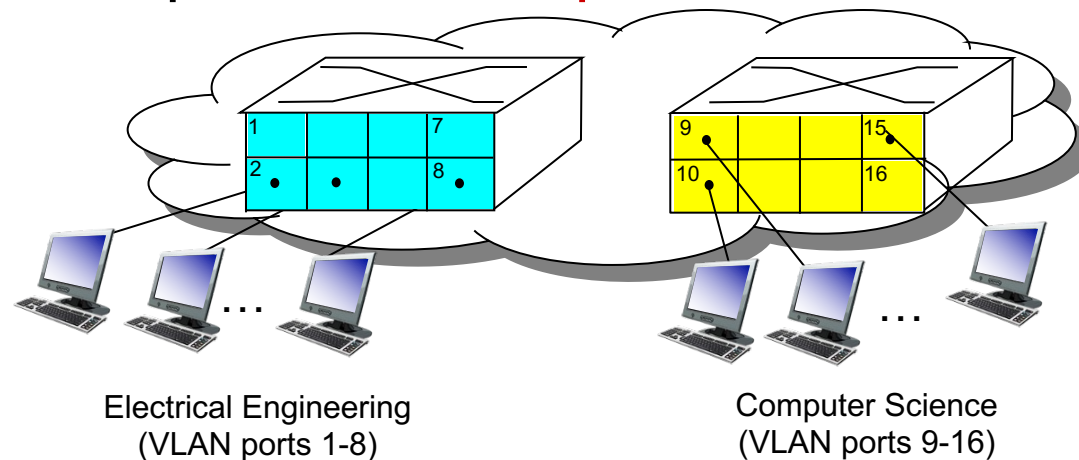

# Port-based VLAN

- **traffic isolation:** frames to/from ports 1-8 can *only* reach ports 1-8
  - can also define VLAN based on MAC addresses of endpoints, rather than switch port
- **dynamic membership:** ports can be dynamically assigned among VLANs
- **forwarding between VLANs:** done via routing (just as with separate switches)
  - in practice vendors sell combined switches plus routers

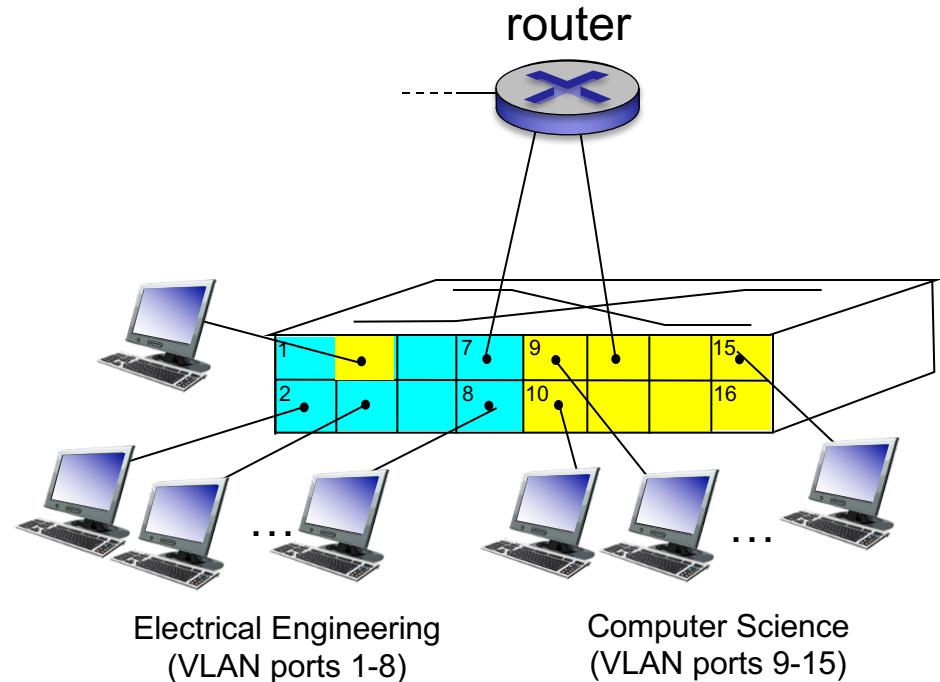

# VLANs spanning multiple switches

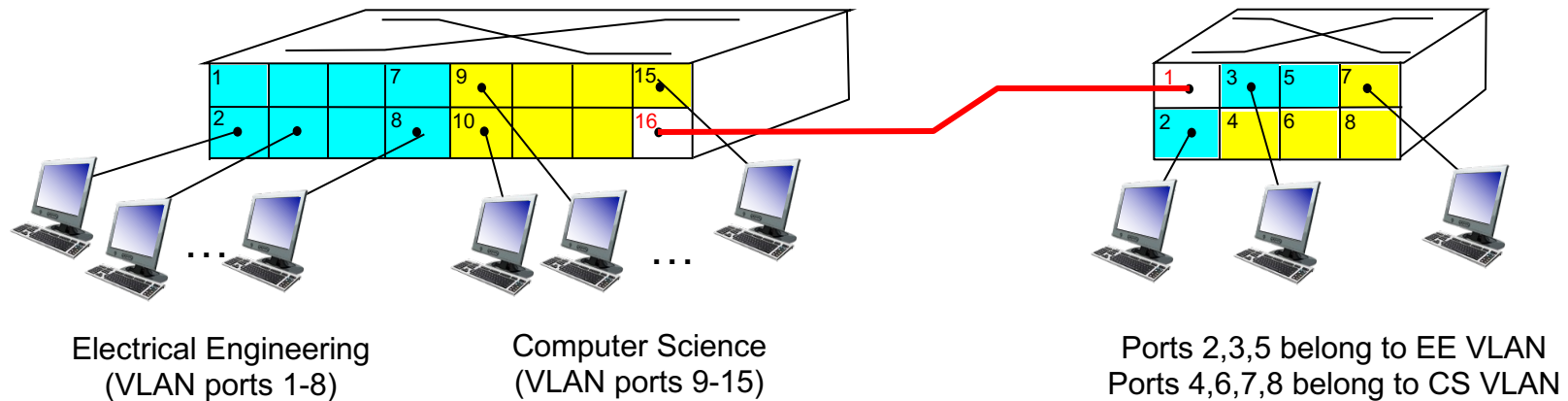

- **trunk port:** carries frames between VLANs defined over multiple physical switches
  - frames forwarded within VLAN between switches can't be vanilla 802.1 frames (must carry VLAN ID info)
  - 802.1q protocol adds/removed additional header fields for frames forwarded between trunk ports

# 802.1Q VLAN frame format

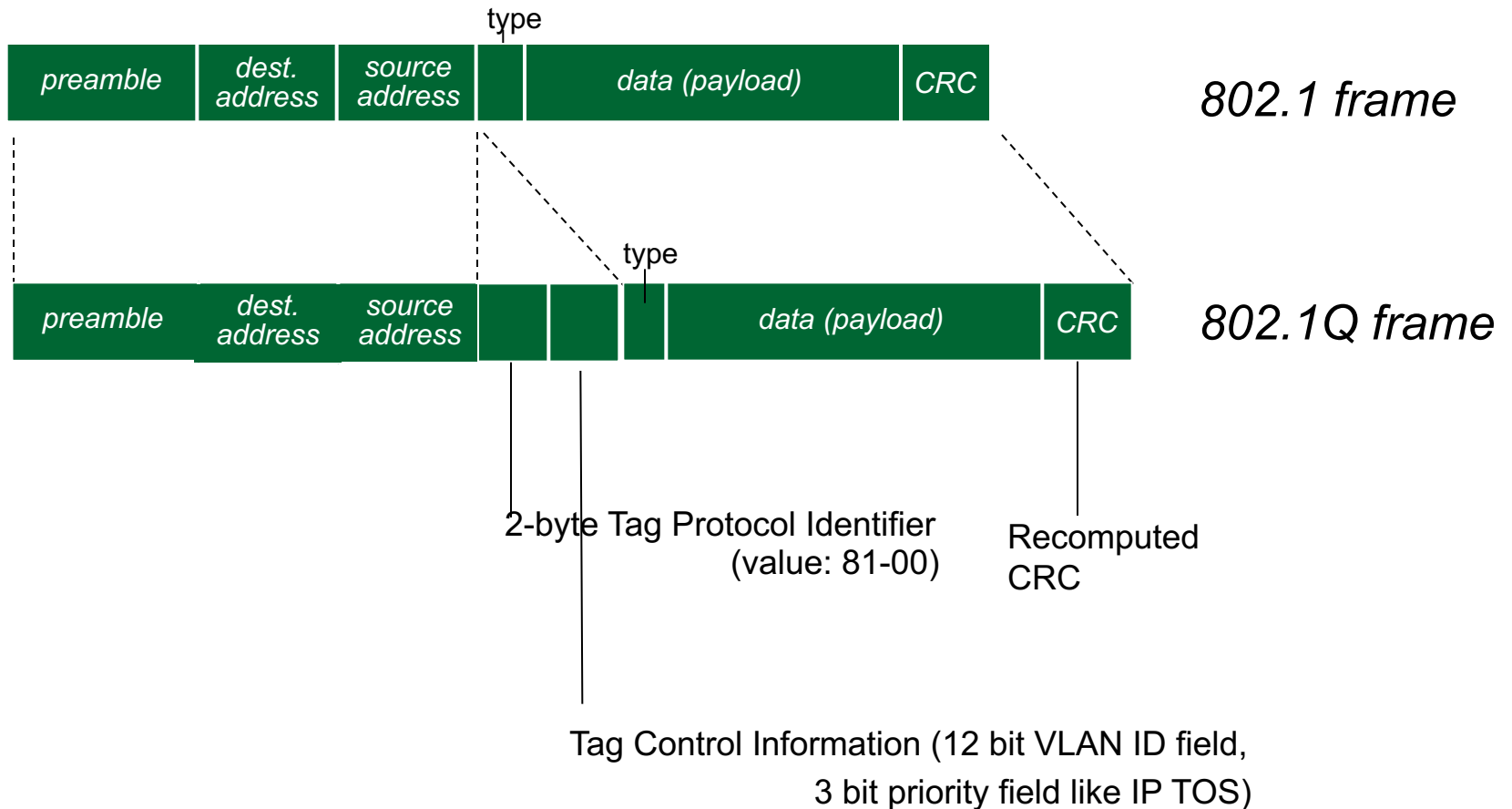



# Link layer, LANs: outline

6.1 introduction, services

6.2 error detection,  
correction

6.3 multiple access  
protocols

6.4 LANs

- addressing, ARP
- Ethernet
- switches
- VLANs

6.5 link virtualization:  
MPLS

6.6 data center  
networking

6.7 a day in the life of a  
web request

# Multiprotocol label switching (MPLS)

- initial goal: high-speed IP forwarding using fixed length label (instead of IP address)
  - fast lookup using fixed length identifier (rather than shortest prefix matching)
  - borrowing ideas from Virtual Circuit (VC) approach
  - but IP datagram still keeps IP address!

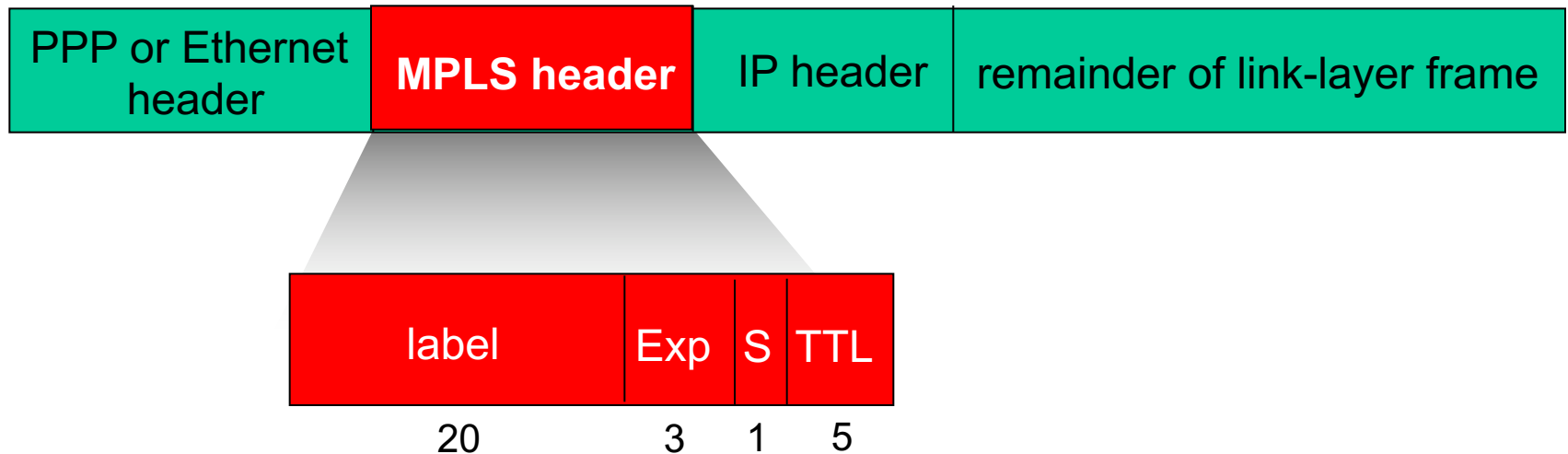

# MPLS capable routers

- a.k.a. label-switched router
- forward packets to outgoing interface based only on label value (*don't inspect IP address*)
  - MPLS forwarding table distinct from IP forwarding tables
- ***flexibility***: MPLS forwarding decisions can *differ* from those of IP
  - use destination *and* source addresses to route flows to same destination differently (traffic engineering)
  - re-route flows quickly if link fails: pre-computed backup paths (useful for VoIP)

# MPLS versus IP paths

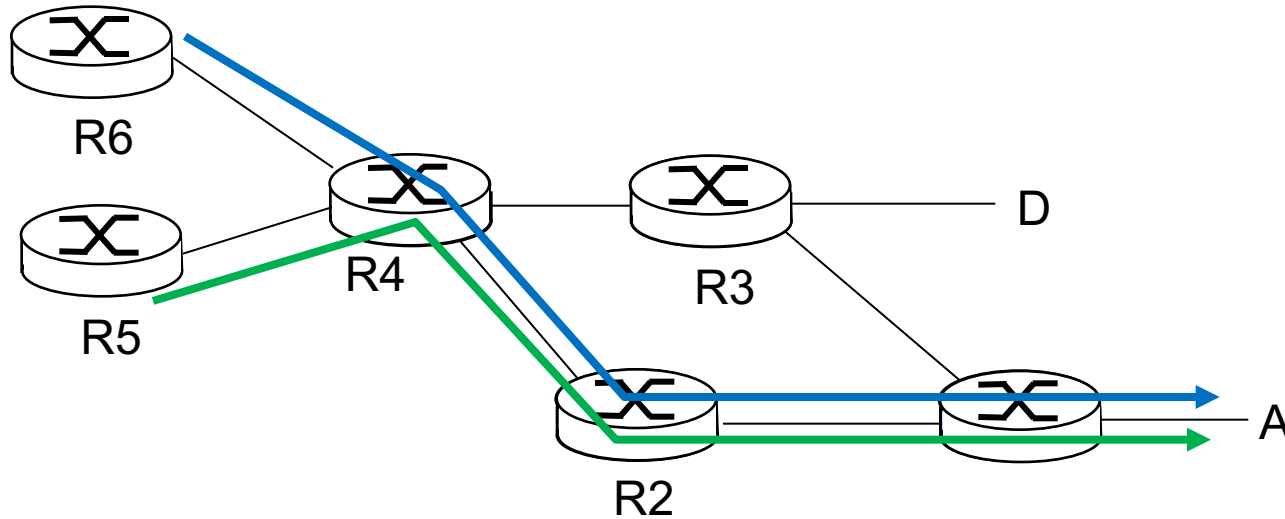

- **IP routing:** path to destination determined by destination address alone



# MPLS versus IP paths

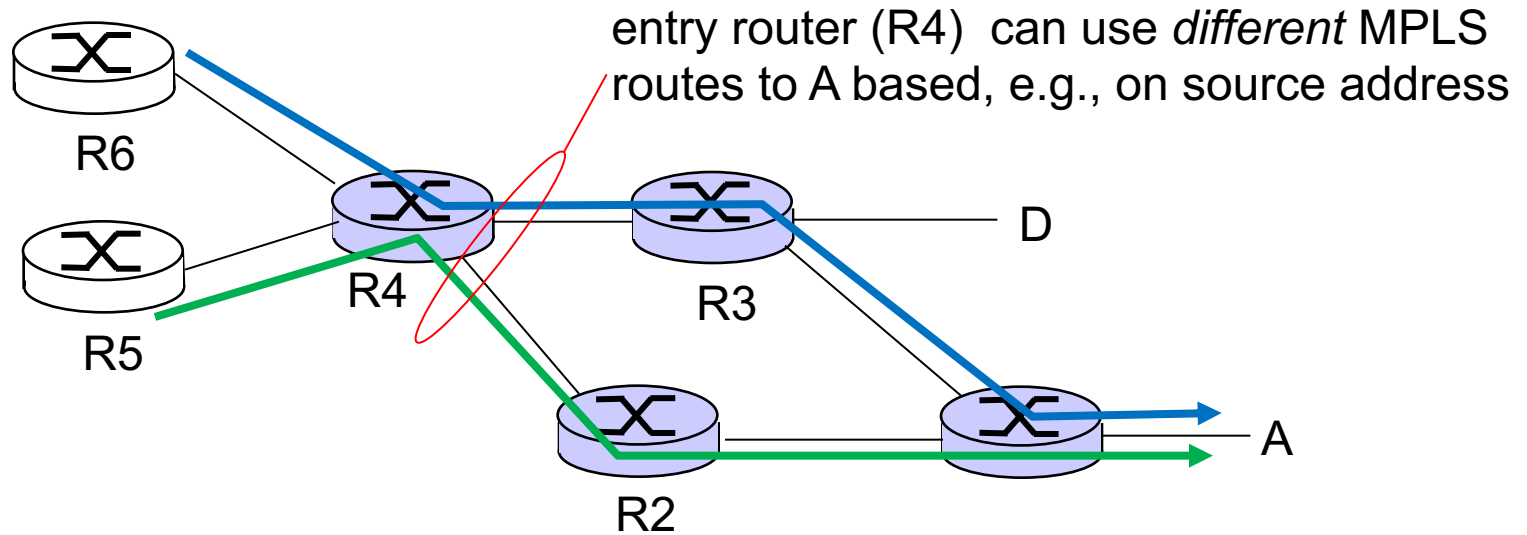

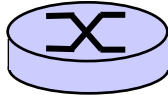
- **IP routing:** path to destination determined by destination address alone  IP-only router
- **MPLS routing:** path to destination can be based on source *and* destination address  MPLS and IP router
  - **fast reroute:** precompute backup routes in case of link failure



# MPLS forwarding tables

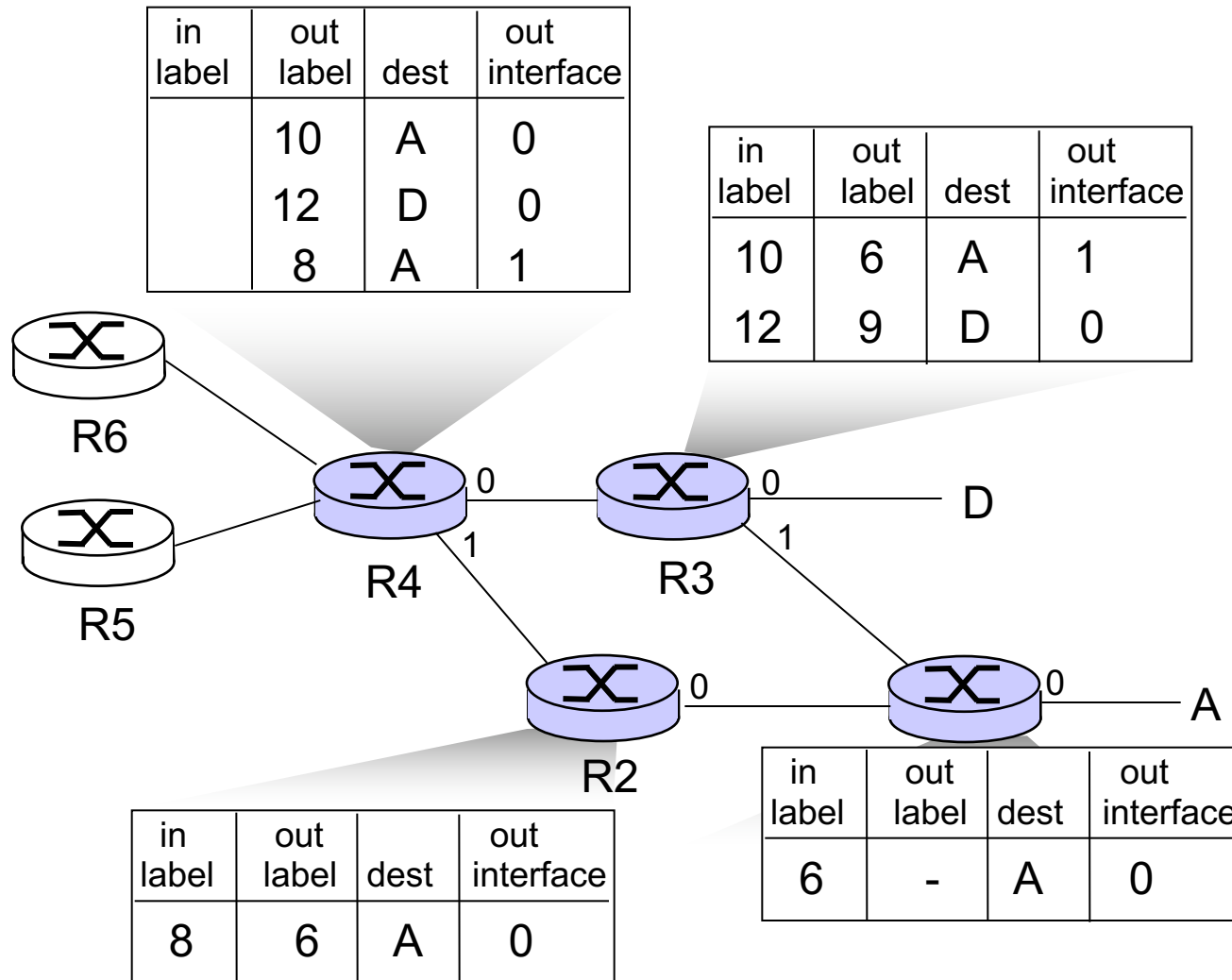

# Link layer, LANs: outline

6.1 introduction, services

6.2 error detection,  
correction

6.3 multiple access  
protocols

6.4 LANs

- addressing, ARP
- Ethernet
- switches
- VLANs

6.5 link virtualization:  
MPLS

6.6 data center  
networking

6.7 a day in the life of a  
web request



# Data center networks

- 10's to 100's of thousands of hosts, often closely coupled, in close proximity:
  - e-business (e.g. Amazon)
  - content-servers (e.g., YouTube, Akamai, Apple, Microsoft)
  - search engines, data mining (e.g., Google)
- challenges:
  - multiple applications, each serving massive numbers of clients
  - managing/balancing load, avoiding processing, networking, data bottlenecks



Inside a 40-ft Microsoft container,  
Chicago data center

# Data center networks

## load balancer: application-layer routing

- receives external client requests
- directs workload within data center
- returns results to external client (hiding data center internals from client)

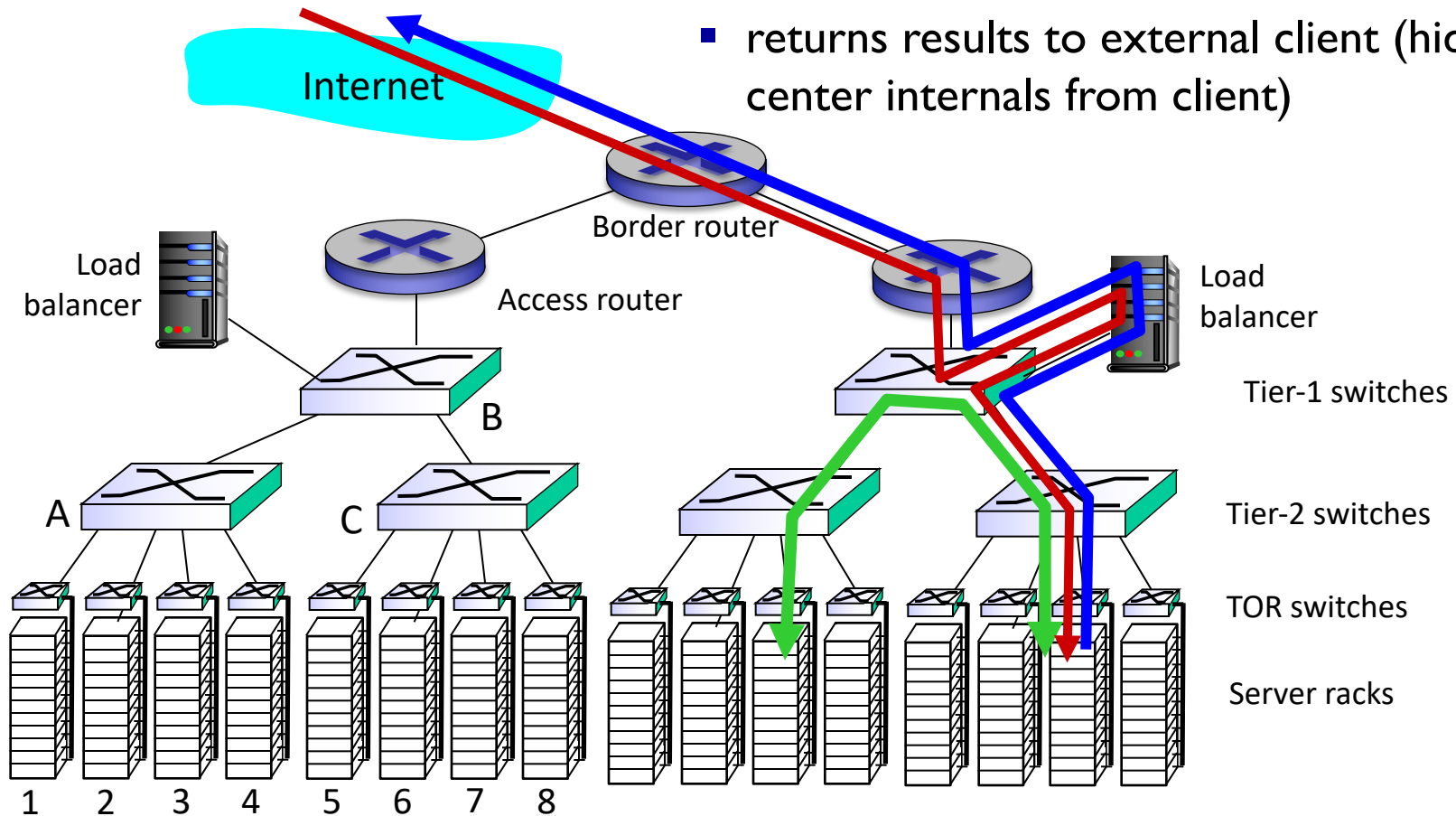

# Data center networks

- rich interconnection among switches, racks:
  - increased throughput between racks (multiple routing paths possible)
  - increased reliability via redundancy

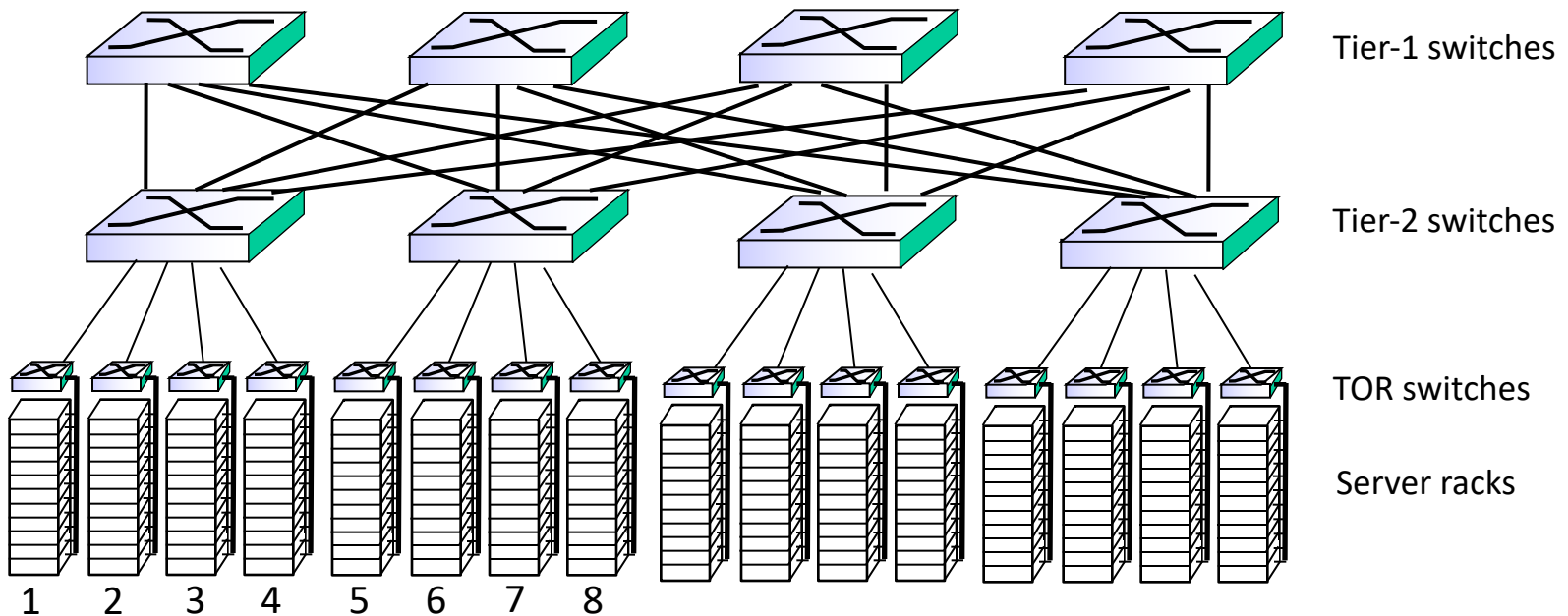

# Link layer, LANs: outline

6.1 introduction, services

6.2 error detection,  
correction

6.3 multiple access  
protocols

6.4 LANs

- addressing, ARP
- Ethernet
- switches
- VLANs

6.5 link virtualization:  
MPLS

6.6 data center  
networking

6.7 a day in the life of a  
web request

## Synthesis: a day in the life of a web request

- journey down protocol stack complete!
  - application, transport, network, link
- putting-it-all-together: synthesis!
  - *goal*: identify, review, understand protocols (at all layers) involved in seemingly simple scenario: requesting www page
  - *scenario*: student attaches laptop to campus network, requests/receives www.google.com

# A day in the life: scenario

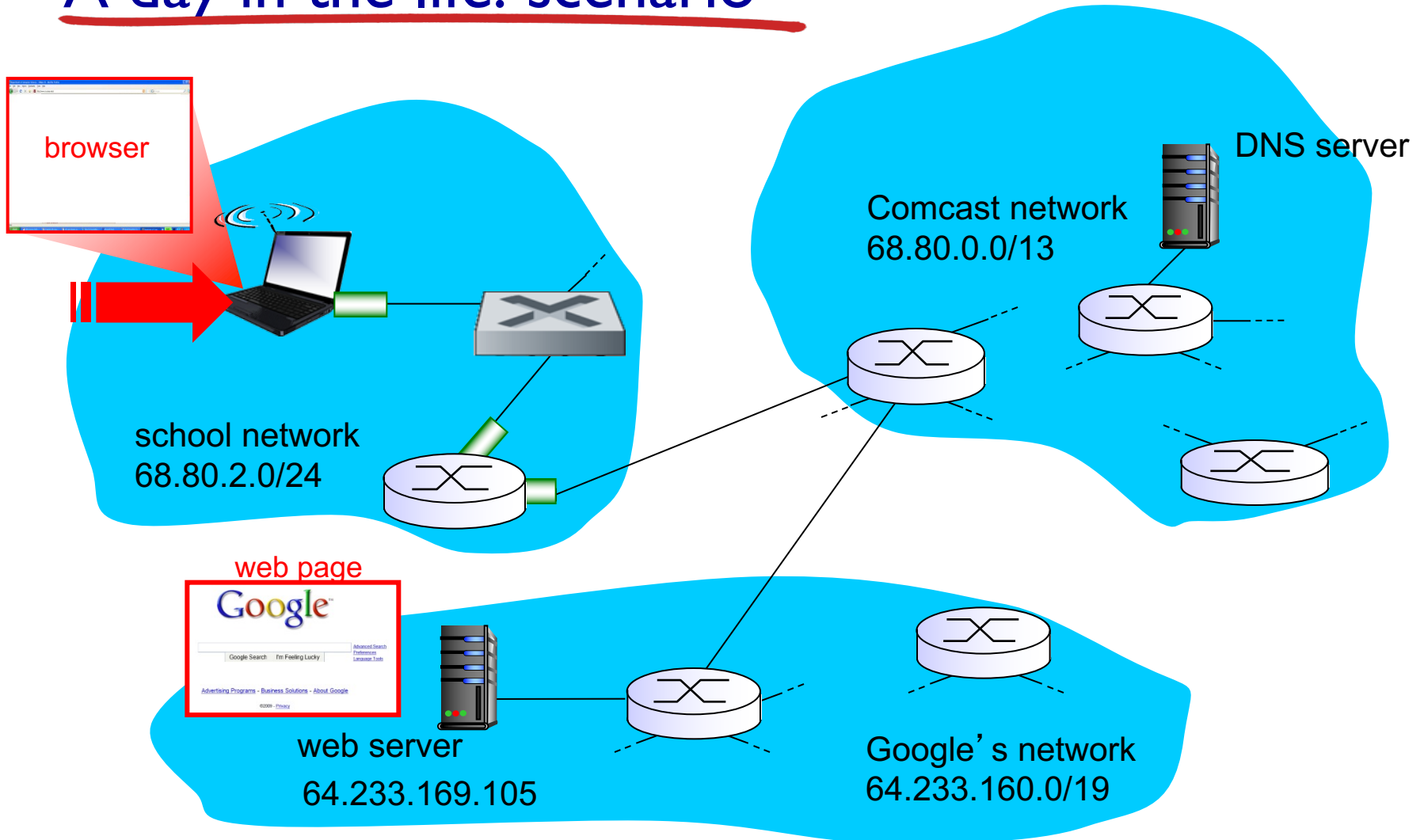

# A day in the life... connecting to the Internet

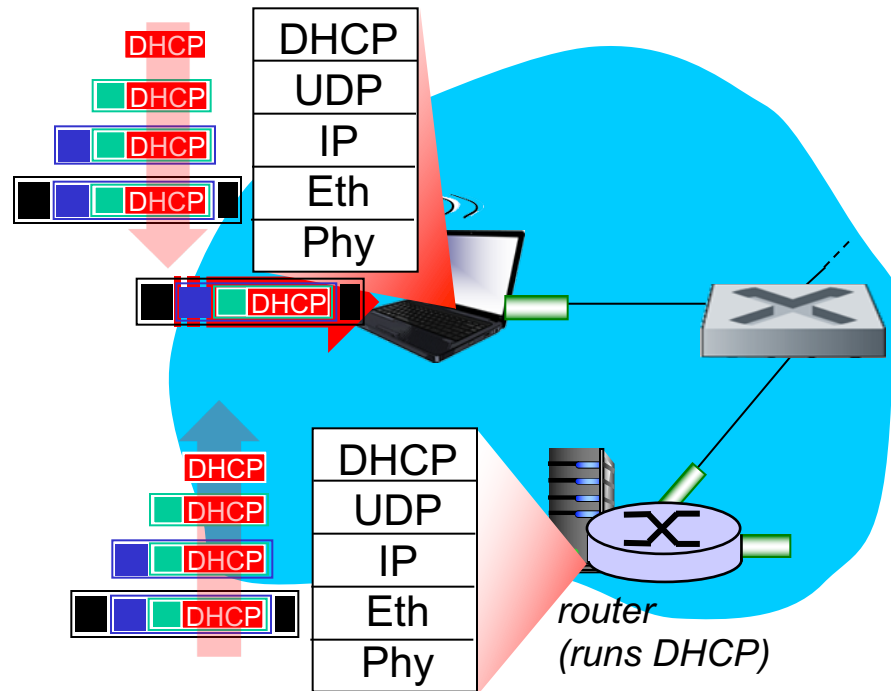

- connecting laptop needs to get its own IP address, addr of first-hop router, addr of DNS server: use *DHCP*
- DHCP request **encapsulated** in **UDP**, encapsulated in **IP**, encapsulated in **802.3** Ethernet
- Ethernet frame **broadcast** (dest: FFFFFFFFFFFFFFFF) on LAN, received at router running **DHCP** server
- Ethernet **demuxed** to IP demuxed, UDP demuxed to DHCP

# A day in the life... connecting to the Internet

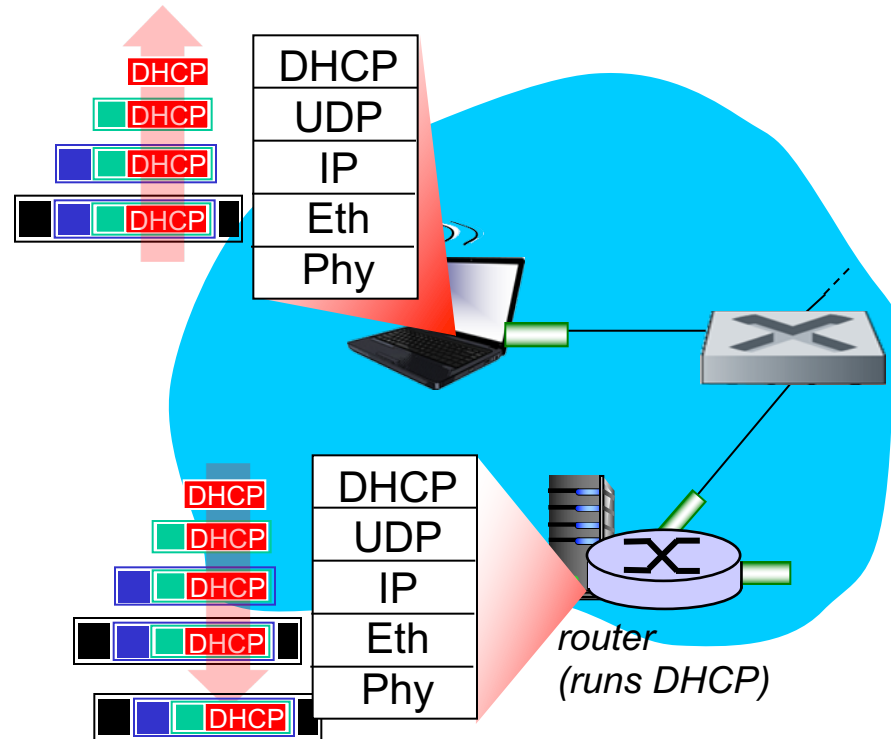

- DHCP server formulates *DHCP ACK* containing client's IP address, IP address of first-hop router for client, name & IP address of DNS server
- encapsulation at DHCP server, frame forwarded (*switch learning*) through LAN, demultiplexing at client
- DHCP client receives DHCP ACK reply

*Client now has IP address, knows name & addr of DNS server, IP address of its first-hop router*



# A day in the life... ARP (before DNS, before HTTP)

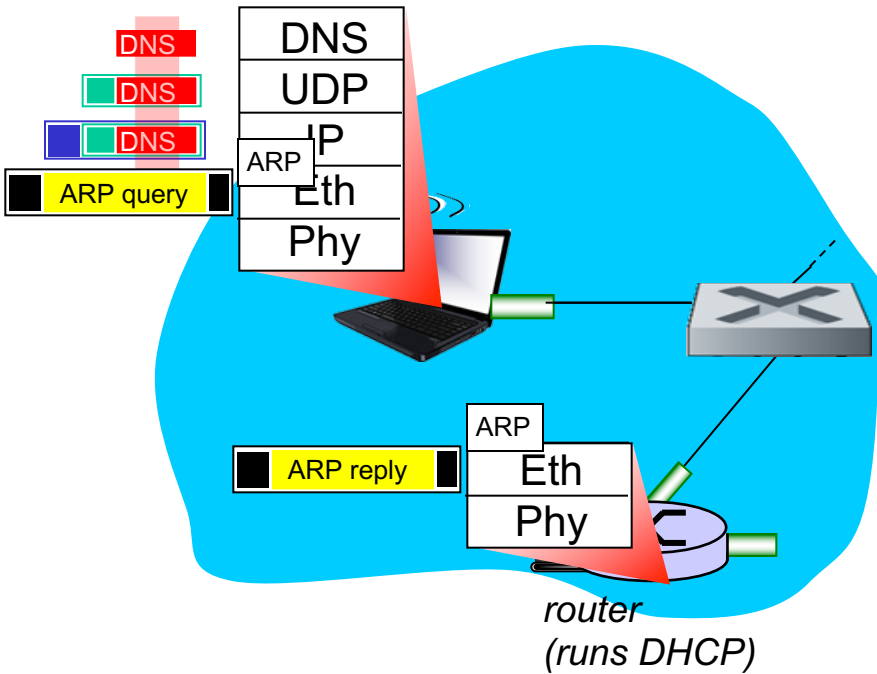

- before sending *HTTP* request, need IP address of `www.google.com`: *DNS*
- DNS query created, encapsulated in UDP, encapsulated in IP, encapsulated in Eth. To send frame to router, need MAC address of router interface: *ARP*
- *ARP query* broadcast, received by router, which replies with *ARP reply* giving MAC address of router interface
- client now knows MAC address of first hop router, so can now send frame containing DNS query

# A day in the life... using DNS

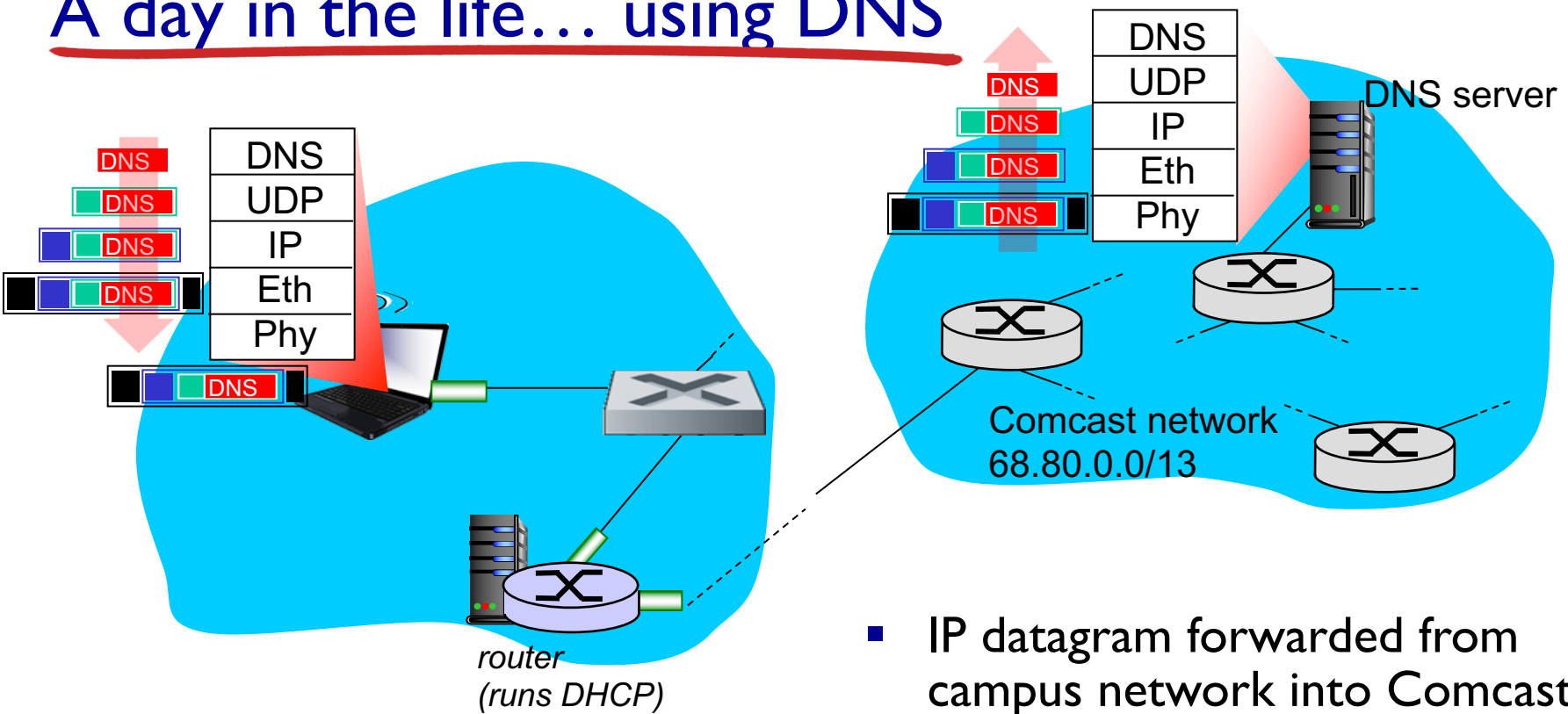

- IP datagram containing DNS query forwarded via LAN switch from client to 1<sup>st</sup> hop router

- IP datagram forwarded from campus network into Comcast network, routed (tables created by **RIP**, **OSPF**, **IS-IS** and/or **BGP** routing protocols) to DNS server
- demuxed to DNS server
- DNS server replies to client with IP address of **www.google.com**

# A day in the life...TCP connection carrying HTTP

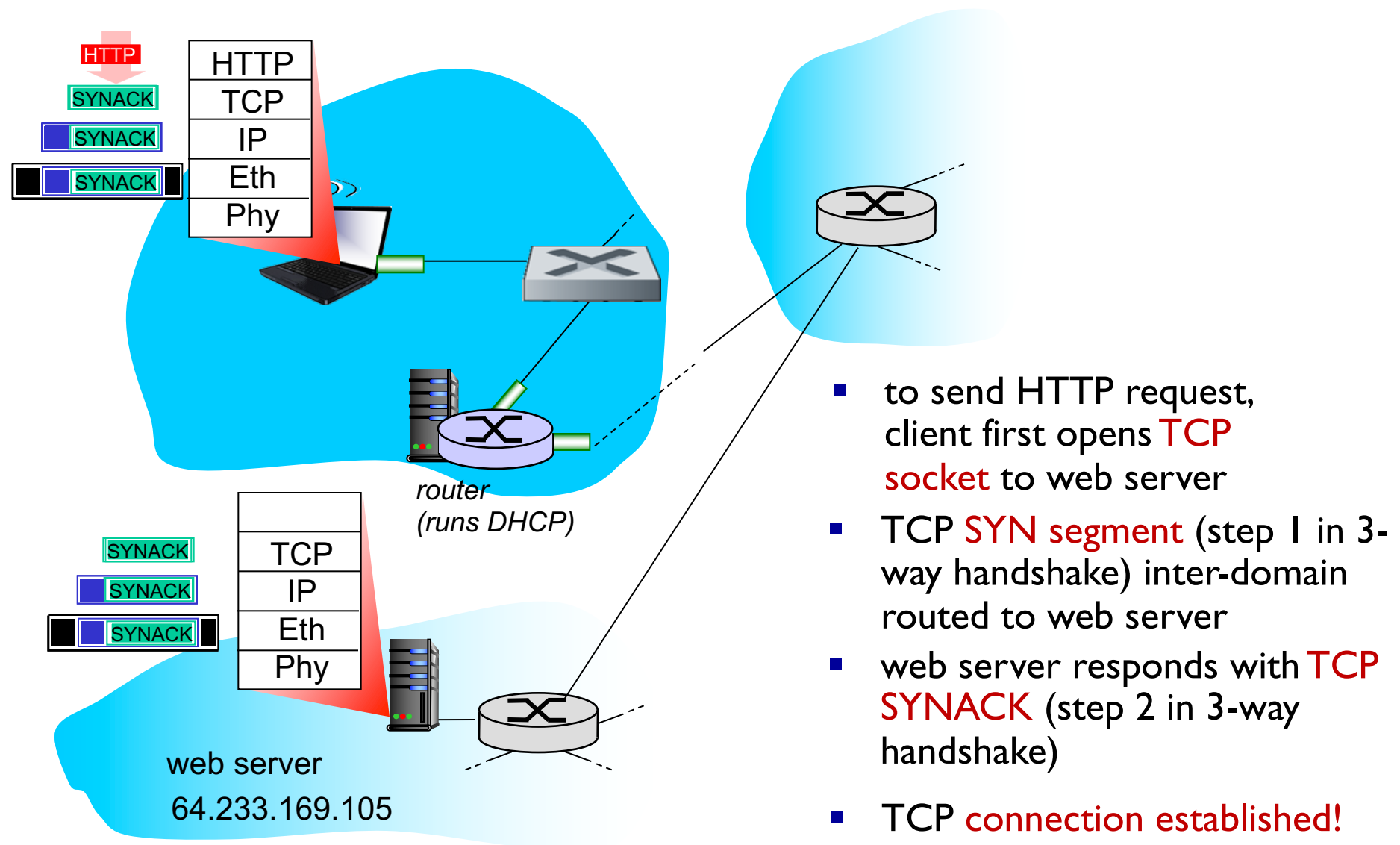

# A day in the life... HTTP request/reply

- web page **finally (!!!)** displayed

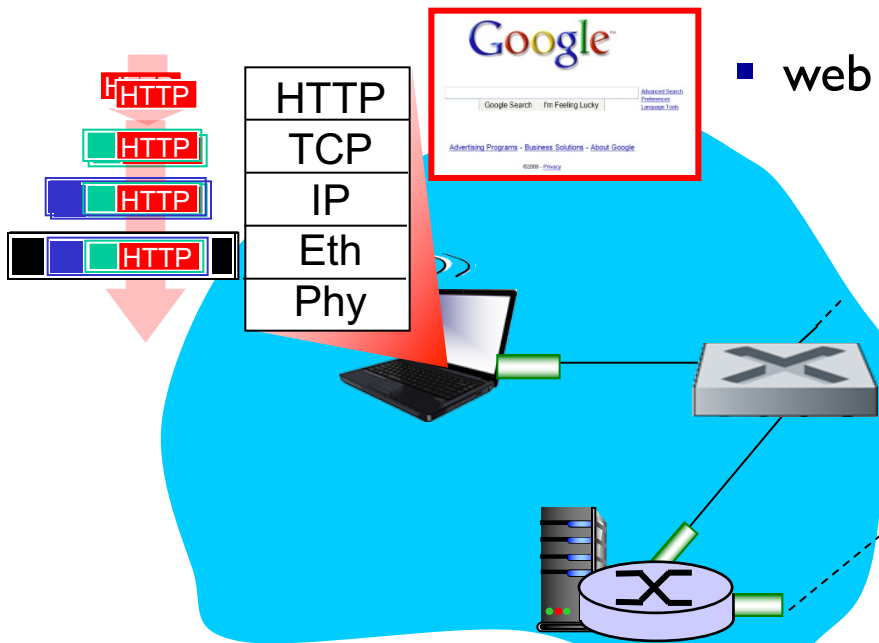

router  
(runs DHCP)

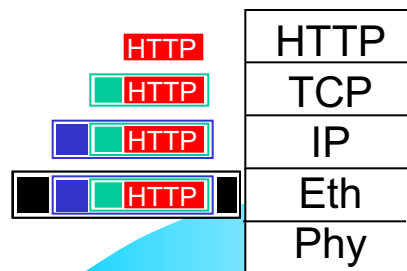

web server  
64.233.169.105

- HTTP request** sent into TCP socket
- IP datagram containing HTTP request routed to `www.google.com`
- web server responds with **HTTP reply** (containing web page)
- IP datagram containing HTTP reply routed back to client

# Chapter 6: Summary

- principles behind data link layer services:
  - error detection, correction
  - sharing a broadcast channel: multiple access
  - link layer addressing
- instantiation and implementation of various link layer technologies
  - Ethernet
  - switched LANS, VLANs
  - virtualized networks as a link layer: MPLS
- synthesis: a day in the life of a web request

# Chapter 6: let's take a breath

- journey down protocol stack *complete* (except PHY)
- solid understanding of networking principles, practice
- ..... could stop here .... but *lots* of interesting topics!
  - wireless
  - multimedia
  - security