

MATRICES

(slightly modified content from Wikipedia articles on matrices [http://en.wikipedia.org/wiki/Matrix \(mathematics\)](http://en.wikipedia.org/wiki/Matrix_(mathematics)))

A *matrix* is a **rectangular array of numbers** or other mathematical objects, for which operations such as [addition](#) and [multiplication](#) are defined. Most of this article focuses on *real matrices*, i.e., matrices whose elements are [real numbers](#). For instance, this is a real matrix:

$$\mathbf{A} = \begin{bmatrix} -1.3 & 0.6 \\ 20.4 & 5.5 \\ 9.7 & -6.2 \end{bmatrix}.$$

The numbers, symbols or expressions in the matrix are called its *entries* or its **elements**. The horizontal and vertical lines of entries in a matrix are called **rows** and **columns**, respectively. The size of a matrix is defined by the number of rows and columns that it contains. **A matrix with m rows and n columns is called an $m \times n$ matrix or m -by- n matrix**, while m and n are called its **dimensions**. For example, the matrix \mathbf{A} above is a 3×2 matrix. Matrices which have a single row are called [row vectors](#), and those which have a single column are called [column vectors](#). A matrix which has the same number of rows and columns is called a [square matrix](#).

Name	Size	Example	Description
Row vector	$1 \times n$	$\begin{bmatrix} 3 & 7 & 2 \end{bmatrix}$	A matrix with one row, sometimes used to represent a vector
Column vector	$n \times 1$	$\begin{bmatrix} 4 \\ 1 \\ 8 \end{bmatrix}$	A matrix with one column, sometimes used to represent a vector
Square matrix	$n \times n$	$\begin{bmatrix} 9 & 13 & 5 \\ 1 & 11 & 7 \\ 2 & 6 & 3 \end{bmatrix}$	A matrix with the same number of rows and columns.

1. Notation

Matrices are commonly written in box brackets:

$$\mathbf{A} = \begin{bmatrix} a_{11} & a_{12} & \cdots & a_{1n} \\ a_{21} & a_{22} & \cdots & a_{2n} \\ \vdots & \vdots & \ddots & \vdots \\ a_{m1} & a_{m2} & \cdots & a_{mn} \end{bmatrix}.$$

The specifics of symbolic matrix notation varies widely, with some prevailing trends. Matrices are usually symbolized using **upper-case** letters (such as **A** in the examples above), while the corresponding **lower-case** letters, with two subscript indices (e.g., a_{11} , or $a_{1,1}$), represent the entries.

The entry in the i -th row and j -th column of a matrix **A** is sometimes referred to as the i,j , (i,j) , or $(i,j)^{\text{th}}$ entry of the matrix, and most commonly denoted as $a_{i,j}$, or a_{ij} . Alternative notations for that entry are $A[i,j]$ or $A_{i,j}$. For example, the (1,3) entry of the following matrix **A** is 5 (also denoted a_{13} , $a_{1,3}$, $A[1,3]$ or $A_{1,3}$):

$$\mathbf{A} = \begin{bmatrix} 4 & -7 & 5 & 0 \\ -2 & 0 & 11 & 8 \\ 19 & 1 & -3 & 12 \end{bmatrix}$$

Sometimes, the entries of a matrix can be defined by a formula such as $a_{i,j} = f(i,j)$. For example, each of the entries of the following matrix **A** is determined by $a_{ij} = i - j$.

$$\mathbf{A} = \begin{bmatrix} 0 & -1 & -2 & -3 \\ 1 & 0 & -1 & -2 \\ 2 & 1 & 0 & -1 \end{bmatrix}$$

In this case, the matrix itself is sometimes defined by that formula, within square brackets or double parenthesis. For example, the matrix above is defined as $\mathbf{A} = [i-j]$. If matrix size is $m \times n$, the above-mentioned formula $f(i,j)$ is valid for any $i = 1, \dots, m$ and any $j = 1, \dots, n$. This can be either specified separately, or using $m \times n$ as a subscript. For instance, the matrix **A** above is 3×4 and can be defined as $\mathbf{A} = [i - j]$ ($i = 1, 2, 3; j = 1, \dots, 4$), or $\mathbf{A} = [i - j]_{3 \times 4}$.

Submatrix

A **submatrix** of a matrix is obtained by deleting any collection of rows and/or columns. For example, from the following 3-by-4 matrix, we can construct a 2-by-3 submatrix by removing row 3 and column 2:

$$\mathbf{A} = \begin{bmatrix} 1 & 2 & 3 & 4 \\ 5 & 6 & 7 & 8 \\ 9 & 10 & 11 & 12 \end{bmatrix} \rightarrow \begin{bmatrix} 1 & 3 & 4 \\ 5 & 7 & 8 \end{bmatrix}.$$

A **principal submatrix** is a square submatrix obtained by removing certain rows and columns. A leading principal submatrix is one in which the first k rows and columns, for some number k , are the ones that remain.

2. Basic operations

There are a number of basic operations that can be applied to modify matrices, called *matrix addition*, *scalar multiplication*, *transposition*, *matrix multiplication*, *row operations*, and *submatrix*.

Operation	Definition	Example
Addition	The <i>sum</i> $\mathbf{A}+\mathbf{B}$ of two m -by- n matrices \mathbf{A} and \mathbf{B} is calculated entrywise: $(\mathbf{A} + \mathbf{B})_{i,j} = \mathbf{A}_{i,j} + \mathbf{B}_{i,j}$, where $1 \leq i \leq m$ and $1 \leq j \leq n$.	$\begin{bmatrix} 1 & 3 & 1 \\ 1 & 0 & 0 \end{bmatrix} + \begin{bmatrix} 0 & 0 & 5 \\ 7 & 5 & 0 \end{bmatrix} = \begin{bmatrix} 1+0 & 3+0 & 1+5 \\ 1+7 & 0+5 & 0+0 \end{bmatrix} = \begin{bmatrix} 1 & 3 & 6 \\ 8 & 5 & 0 \end{bmatrix}$
Scalar multiplication	The product $c\mathbf{A}$ of a number c (also called a scalar) and a matrix \mathbf{A} is computed by multiplying every entry of \mathbf{A} by c : $(c\mathbf{A})_{i,j} = c \cdot \mathbf{A}_{i,j}$.	$2 \cdot \begin{bmatrix} 1 & 8 & -3 \\ 4 & -2 & 5 \end{bmatrix} = \begin{bmatrix} 2 \cdot 1 & 2 \cdot 8 & 2 \cdot -3 \\ 2 \cdot 4 & 2 \cdot -2 & 2 \cdot 5 \end{bmatrix} = \begin{bmatrix} 2 & 16 & -6 \\ 8 & -4 & 10 \end{bmatrix}$
Transposition	This operation is called <i>scalar multiplication</i> . The <i>transpose</i> of an m -by- n matrix \mathbf{A} is the n -by- m matrix \mathbf{A}^T formed by turning rows into columns and vice versa: $(\mathbf{A}^T)_{i,j} = \mathbf{A}_{j,i}$.	$\begin{bmatrix} 1 & 2 & 3 \\ 0 & -6 & 7 \end{bmatrix}^T = \begin{bmatrix} 1 & 0 \\ 2 & -6 \\ 3 & 7 \end{bmatrix}$

Familiar properties of numbers extend to these operations of matrices: for example, addition is [commutative](#), i.e., the matrix sum does not depend on the order of the summands: $\mathbf{A} + \mathbf{B} = \mathbf{B} + \mathbf{A}$. The transpose is compatible with addition and scalar multiplication, as expressed by $(c\mathbf{A})^T = c(\mathbf{A}^T)$ and $(\mathbf{A} + \mathbf{B})^T = \mathbf{A}^T + \mathbf{B}^T$. Finally, $(\mathbf{A}^T)^T = \mathbf{A}$.

Matrix multiplication

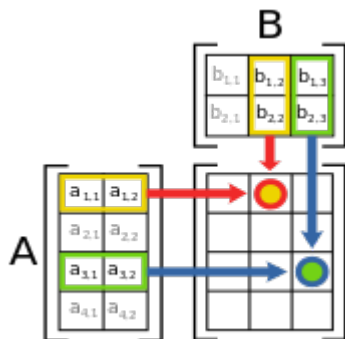

Schematic depiction of the matrix product \mathbf{AB} of two matrices \mathbf{A} and \mathbf{B} .

Multiplication of two matrices is defined if and only if the number of columns of the left matrix is the same as the number of rows of the right matrix. If **A** is an m -by- n matrix and **B** is an n -by- p matrix, then their *matrix product* **AB** is the m -by- p matrix whose entries are given by *dot product* of the corresponding row of **A** and the corresponding column of **B**:

$$[\mathbf{AB}]_{i,j} = A_{i,1}B_{1,j} + A_{i,2}B_{2,j} + \cdots + A_{i,n}B_{n,j} = \sum_{r=1}^n A_{i,r}B_{r,j},$$

where $1 \leq i \leq m$ and $1 \leq j \leq p$.^[12] For example, the underlined entry 2340 in the product is calculated as $(2 \times 1000) + (3 \times 100) + (4 \times 10) = 2340$:

$$\begin{bmatrix} \underline{2} & \underline{3} & \underline{4} \\ 1 & 0 & 0 \end{bmatrix} \begin{bmatrix} 0 & \underline{1000} \\ 1 & \underline{100} \\ 0 & \underline{10} \end{bmatrix} = \begin{bmatrix} 3 & \underline{2340} \\ 0 & 1000 \end{bmatrix}.$$

Matrix multiplication satisfies the rules $(\mathbf{AB})\mathbf{C} = \mathbf{A}(\mathbf{BC})$ (*associativity*), and $(\mathbf{A}+\mathbf{B})\mathbf{C} = \mathbf{AC}+\mathbf{BC}$ as well as $\mathbf{C}(\mathbf{A}+\mathbf{B}) = \mathbf{CA}+\mathbf{CB}$ (*left and right distributivity*), whenever the size of the matrices is such that the various products are defined.^[13] The product **AB** may be defined without **BA** being defined, namely if **A** and **B** are m -by- n and n -by- k matrices, respectively, and $m \neq k$. Even if both products are defined, they need not be equal, i.e., generally

$$\mathbf{AB} \neq \mathbf{BA},$$

i.e., *matrix multiplication is not commutative*, in marked contrast to (rational, real, or complex) numbers whose product is independent of the order of the factors. An example of two matrices not commuting with each other is:

$$\begin{bmatrix} 1 & 2 \\ 3 & 4 \end{bmatrix} \begin{bmatrix} 0 & 1 \\ 0 & 0 \end{bmatrix} = \begin{bmatrix} 0 & 1 \\ 0 & 3 \end{bmatrix}, \text{ whereas } \begin{bmatrix} 0 & 1 \\ 0 & 0 \end{bmatrix} \begin{bmatrix} 1 & 2 \\ 3 & 4 \end{bmatrix} = \begin{bmatrix} 3 & 4 \\ 0 & 0 \end{bmatrix}.$$

The following property for transpose of the matrix product can be shown to hold: $(\mathbf{AB})^T = \mathbf{B}^T\mathbf{A}^T$

Row and Column operations

There are three types of row operations on a matrix **A** of dimension m -by- n that can be produced *by multiplying it from left* with an elementary matrix **E** of dimension m -by- m , $\mathbf{E}\mathbf{A}$:

1. *row switching*, that is interchanging two rows of a matrix.
2. *row addition*, that is adding a row to another.
3. *row multiplication*, that is multiplying all entries of a row by a non-zero constant.

In [mathematics](#), an **elementary matrix** is a [matrix](#) which differs from the [identity matrix](#) by one single elementary row operation. Repeated multiplication of the identity matrix by the elementary matrices can generate any [invertible matrix](#) (definition of the inverse matrix will come later). **Left multiplication** (pre-multiplication) by an elementary matrix represents **elementary row operations**, while **right multiplication** (post-multiplication) represents **elementary column operations**. Elementary row operations are the basis of the very important method of [Gaussian elimination](#) (will be explained below).

Row-switching transformations

The first type of row operation on a matrix \mathbf{A} switches all matrix elements on row i with their counterparts on row j . The corresponding elementary matrix is obtained by swapping row i and row j of the [identity matrix](#).

$$T_{i,j} = \begin{bmatrix} 1 & & & & & \\ & \ddots & & & & \\ & & 0 & & 1 & \\ & & & \ddots & & \\ & & 1 & & 0 & \\ & & & & & \ddots & \\ & & & & & & 1 \end{bmatrix}$$

So $\mathbf{T}_{ij} \cdot \mathbf{A}$ is the matrix produced by exchanging row i and row j of \mathbf{A} .

Row-multiplying transformations

The next type of row operation on a matrix \mathbf{A} multiplies all elements on row i by m where m is a non-zero [scalar](#) (usually a real number). The corresponding elementary matrix is a diagonal matrix, with diagonal entries 1 everywhere except in the i th position, where it is m .

$$T_i(m) = \begin{bmatrix} 1 & & & & & \\ & \ddots & & & & \\ & & 1 & & & \\ & & & m & & \\ & & & & 1 & \\ & & & & & \ddots & \\ & & & & & & 1 \end{bmatrix}$$

So $\mathbf{T}_i(m) \cdot \mathbf{A}$ is the matrix produced from \mathbf{A} by multiplying row i by m .

Row-addition transformations

The final type of row operation on a matrix \mathbf{A} adds row j multiplied by a scalar m to row i . The corresponding elementary matrix is the identity matrix but with an m in the (i,j) position.

$$T_{i,j}(m) = \begin{bmatrix} 1 & & & & & \\ & \ddots & & & & \\ & & 1 & & & \\ & & & \ddots & & \\ & & m & & 1 & \\ & & & & & \ddots \\ & & & & & & 1 \end{bmatrix}$$

So $\mathbf{T}_{i,j}(m) \cdot \mathbf{A}$ is the matrix produced from \mathbf{A} by adding m times row j to row i .